



Parts Manual

Mfg. No: 1696257-01
BP2132SE, B&S 21 Gross TP 32" Dual
Stage Snowthrower (CE) (2013)

Model Components	Page
Auger Drive Group.....	4
Auger Housing Group.....	6
Chute & Rotation Group - Full Electric.....	8
Decals Group.....	10
Engine & Frame Group - 21TP.....	12
Gear Case Assembly (1732303).....	16
Handle & Controls Group.....	18
Traction Drive Group.....	22
Wheels and Tires Group.....	26
Torque Specification Chart.....	28

Not For
In Reproduction

Auger Drive Group

Note: Unless noted otherwise, use the standard torque specifications

Mfg. No: 1696257-01

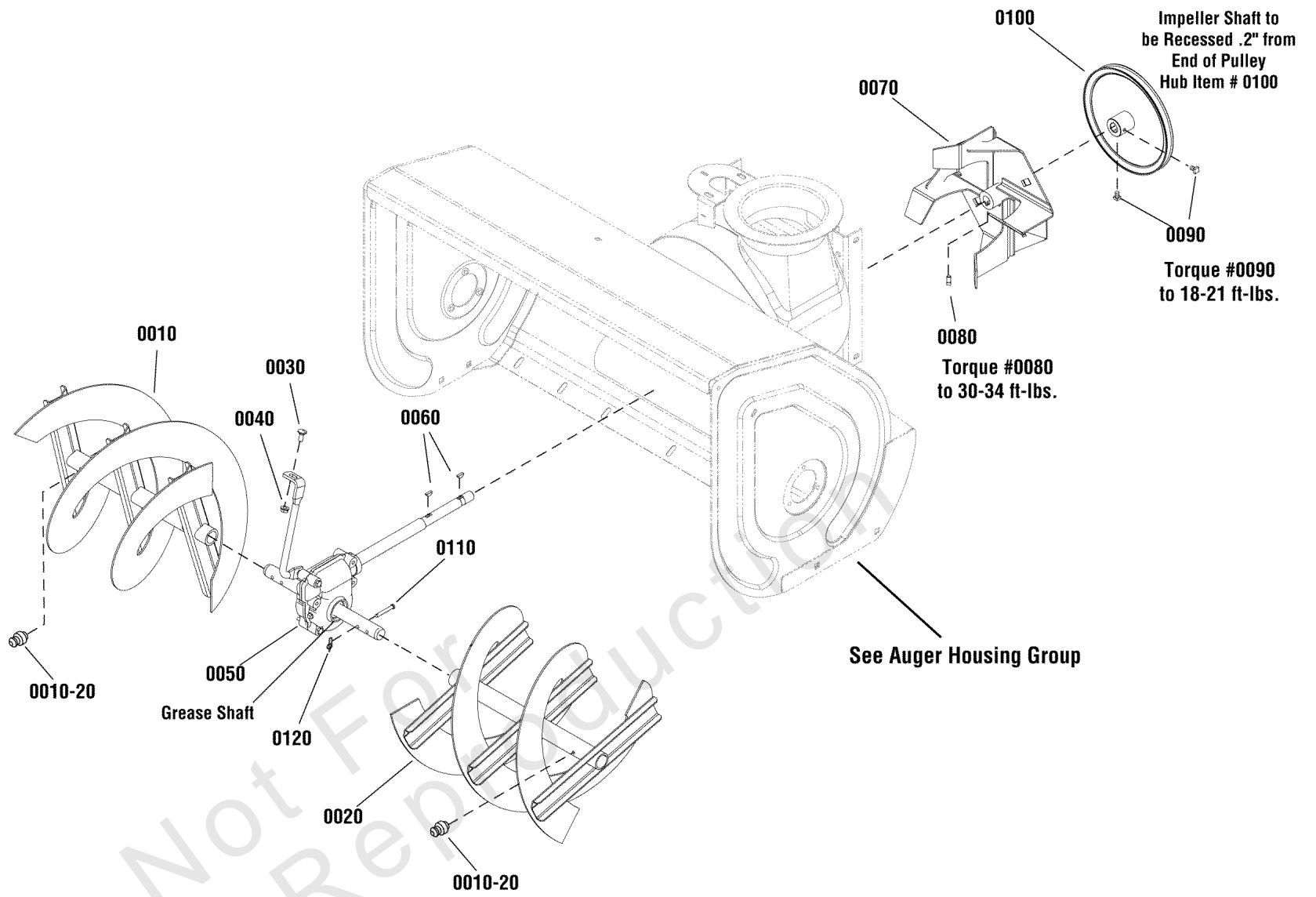

Auger Drive Group

REF NO	PART NO	QTY	DESCRIPTION
0010	1734678BJYP	1	AUGER ASSEMBLY, R.H.
0020	1734677BJYP	1	AUGER ASSEMBLY, L.H.
0010-20	2821133SM	2	FITTING, Grease
0030	1931333SM	1	BOLT, Carriage, Short Neck, 5/16-18 x 3/4, G5
0040	1931277SM	1	NUT, Hex Flange, Whiz Lock, 5/16-18
0050	1732303SM	1	GEAR BOX ASSEMBLY
0060	431787MA	2	KEY, Woodruff
0070	1612187BJYP	1	IMPELLER
0080	1960474SM	1	SCREW, Set, 3/8-16 x 1/2, G8
0090	1928721SM	2	SCREW, Set, 5/16-18 x 1/2, G8
0100	1732468SM	1	PULLEY
0110	1739295YP	2	PIN, Shear
0120	1739292YP	2	PIN, Bow Tie, Cotter

Not For In Reproduction

Auger Housing Group

Note: Unless noted otherwise, use the standard torque specifications

Mfg. No: 1696257-01

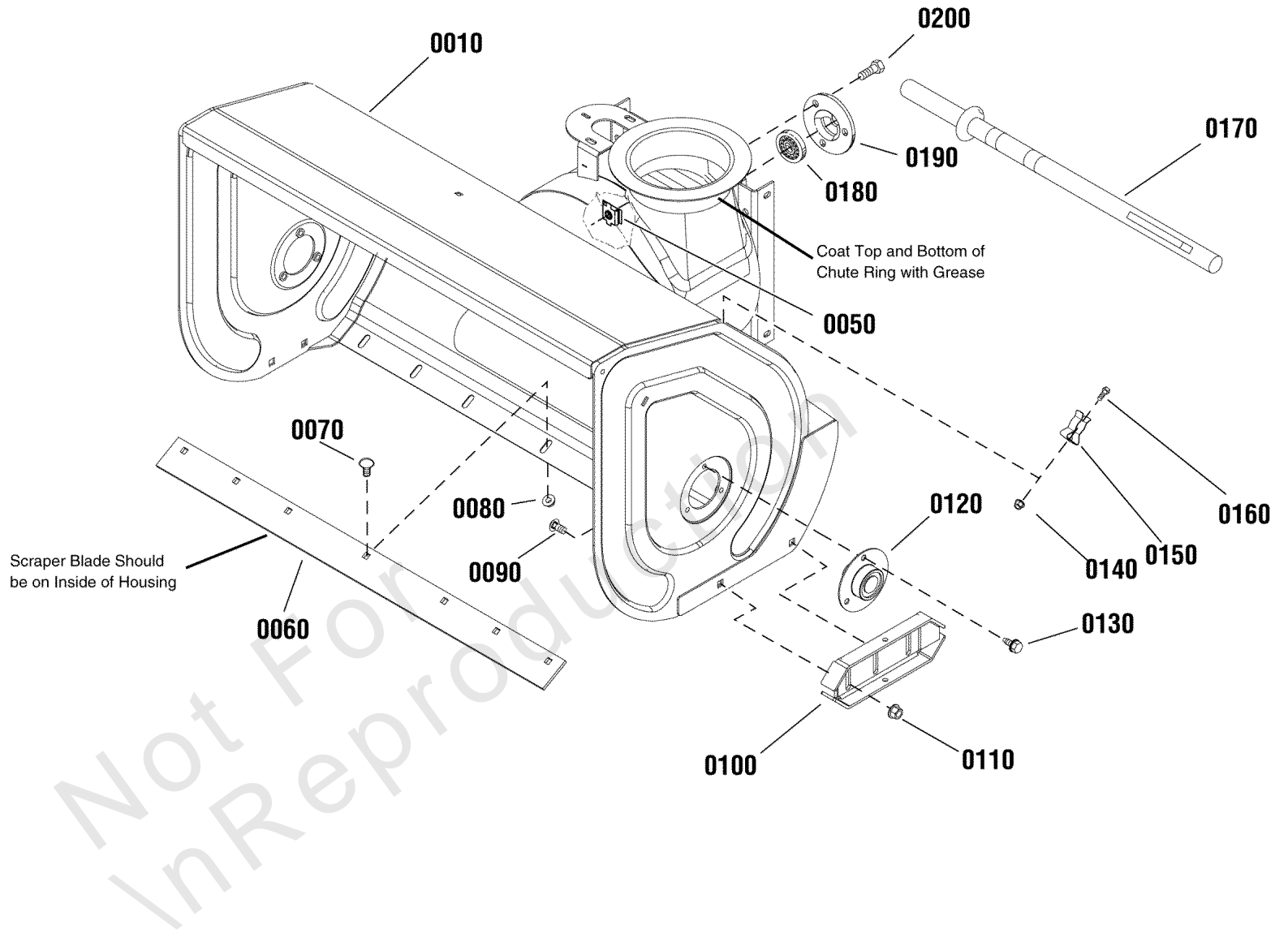

Auger Housing Group

REF NO	PART NO	QTY	DESCRIPTION
0010	1687689YP	1	AUGER HOUSING ASSEMBLY, 32"
0050	1930659SM	3	RETAINER, Nut, 5/16-18
0060	1709948BMYP	1	BLADE, Scraper, 32"
0070	340720MA	7	BOLT, Carriage, 5/16-18 x 3/4
0080	1935048SM	7	NUT, Hex Flange Two Way Lock, 5/16-18
0090	1960702SM	4	BOLT, Carriage, 3/8-16 x 1
0100	1725747BMYP	2	SHOE, Skid
0110	1960687SM	4	NUT, Hex Flange, 3/8-16
0120	1734645SM	2	BEARING ASSEMBLY, Ball, With Flange & Roll Pin
0130	1664847SM	6	SCREW, Hex Washer Head, Taptite, 5/16-18 x 3/4
0140	15X146MA	2	NUT, Nylock, 10 x 24
0150	1736620YP	2	CLAMP, Spring
0160	1960569SM	2	SCREW, Truss Head Torx, 10-24 x 3/8
0170	1736094YP	1	STICK, Cleanout, With Brush
0180	2108202SM	1	BEARING, Ball, 3/4ID x 1-3/4OD x 5/8 Long
0190	1665982SM	1	RETAINER, Bearing
0200	1960738SM	3	SCREW, Hex Flange, 5/16-18 x 3/4

Not For In-Plant Production

Chute & Rotation Group - Full Electric

Note: Unless noted otherwise, use the standard torque specifications

Mfg. No: 1696257-01

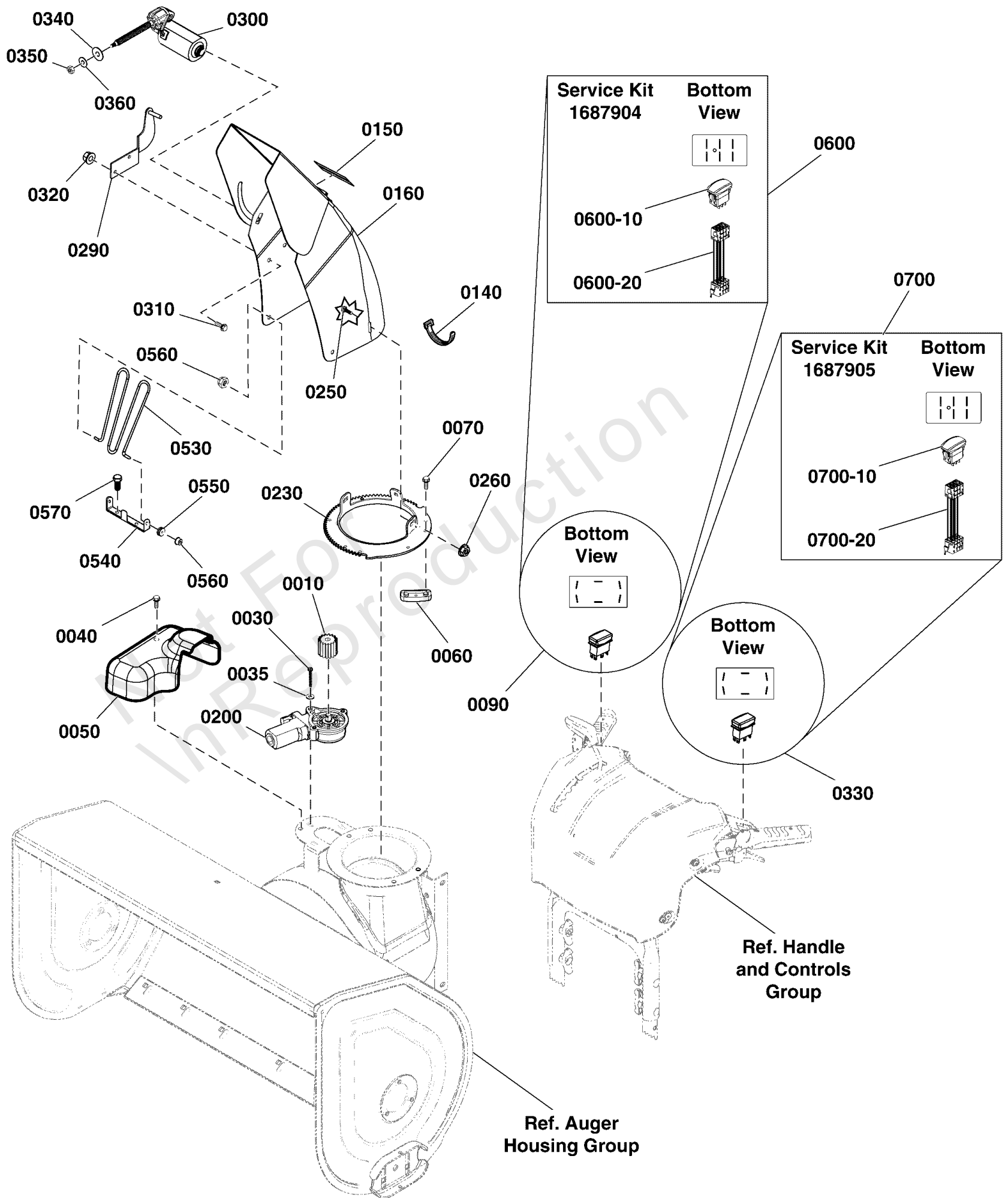

Chute & Rotation Group - Full Electric

REF NO	PART NO	QTY	DESCRIPTION
0010	1728967SM	1	PINION
0030	1739621YP	3	SCREW, Torx Button Head, M5 x .8 x 14
0035	7091552SM	3	WASHER, Flat, 7/32
0040	1925592SM	1	SCREW, Hex Washer Head, Taptite, 1/4-20 x 3/4
0050	1752877YP	1	COVER, Electric Chute Rotation
0060	7011938SM	3	RETAINER, Spout
0070	1960001SM	6	SCREW, Hex Washer Head, Plastite, 10-14 x 5/8
0090	1752240YP	1	SWITCH, Chute Rotation -(-Used Before Serial No. 2017430819) (Order 0600 When Bottom View of Switch Terminal Pattern Matches 0090.)
0140	1701011SM	1	TIE, Self Locking, 15" Long
0150	1733601SM	2	DECAL, Hinge
0160	1752841AYP	1	CHUTE
0200	1739309YP	1	MOTOR, Chute Rotation
0230	1737962BMYP	1	GEAR, Chute
0250	703101	4	BOLT, Carriage, 1/4-20 x 3/4 , GR5
0260	1960685SM	4	NUT, Hex, KEPS, Conical, 1/4-20
0290	1738267BMYP	1	BRACKET, Weld Stud
0300	1737941YP	1	MOTOR, Chute Deflector
0310	1960715SM	2	SCREW, Truss Head, Torx Drive, 1/4-20 x 3/4
0320	1960694SM	2	NUT, Hex Flange, , ESNA, 1/4-20
0330	1737379YP	1	SWITCH, Chute Deflector -(-Used Before Serial No. 2017430819) (Order 0700 When Bottom View of Switch Terminal Pattern Matches 0330.)
0340	1738244YP	1	WASHER, Rubber
0350	1738245YP	1	NUT, LH
0360	703332	1	WASHER, Flat, 1/4
0530	1733475SM	1	GUARD, Chute
0540	1752883YP	1	BRACKET, Chute Guard (CE/Export)
0550	1738174YP	2	GROMMET
0560	1960140SM	2	NUT, Push, 3/16
0570	1925003SM	2	CAPSCREW, Hex Washer Head, Taptite, 1/4-20 x 1/2
0600	1687904	1	WIRE HARNESS ADAPTER KIT, CHUTE ROTATION -(-Used Before Serial No. 2017430819) (Order 0600-10 When Bottom View of Switch Terminal Pattern Matches 0600.)
0600-10	709954	1	SWITCH, Chute Rotation -(-Used After Serial No. 2017430818)
0600-20	84003010	1	HARNESS, Wire -(-Used Before Serial No. 2017430819)
0700	1687905	1	WIRE HARNESS ADAPTER KIT, DEFLECTOR CONT -(-Used Before Serial No. 2017430819) (Order 0700-10 When Bottom View of Switch Terminal Pattern Matches 0700.)
0700-10	709955	1	SWITCH, Deflector Control -(-Used After Serial No. 2017430818)
0700-20	84003010	1	HARNESS, Wire -(-Used Before Serial No. 2017430819)

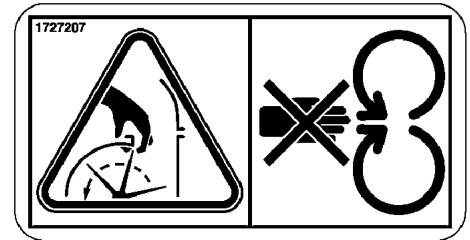
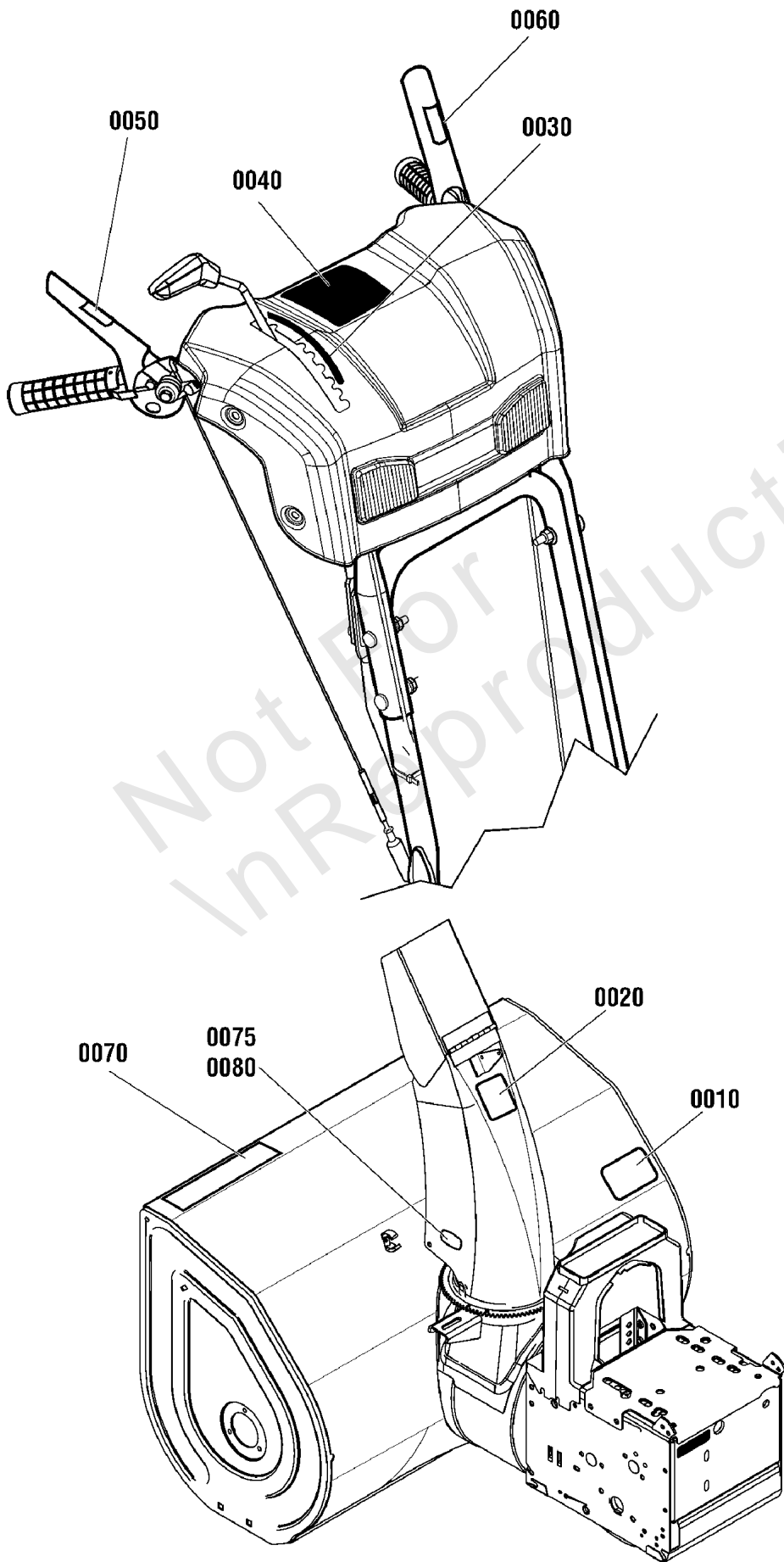

0020

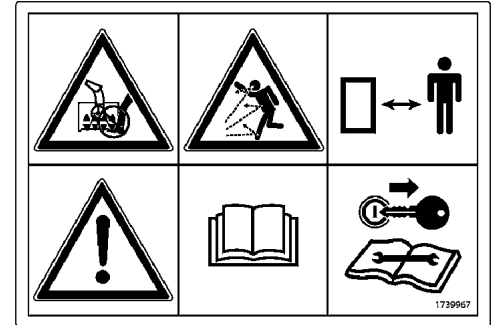

0010



0050



0060

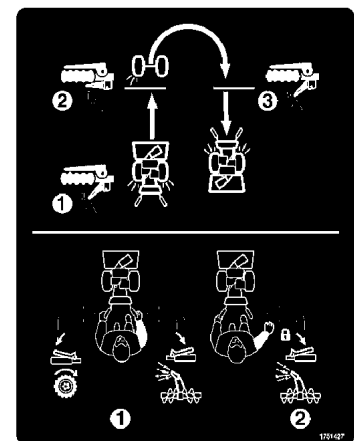

0040



0070

Decals Group

REF NO	PART NO	QTY	DESCRIPTION
0010	1737867YP	1	DECAL, Danger Auger Icons
0020	1727207SM	1	DECAL, Chute Warning, Export
0030	1751582YP	1	DECAL, Gear Shift
0040	1751427YP	1	DECAL, Controls
0050	1737869YP	1	DECAL, Auger Control Symbols
0060	1737870YP	1	DECAL, Traction Control Symbols
0070	1755171YP	1	DECAL, Auger Housing, BP2132SE
0075	1750926YP	1	DECAL, Logo, Chute, LH
0080	1750927YP	1	DECAL, Logo, Chute, RH

Not For In Reproduction

Engine & Frame Group - 21TP

Note: Unless noted otherwise, use the standard torque specifications

Mfg. No: 1696257-01

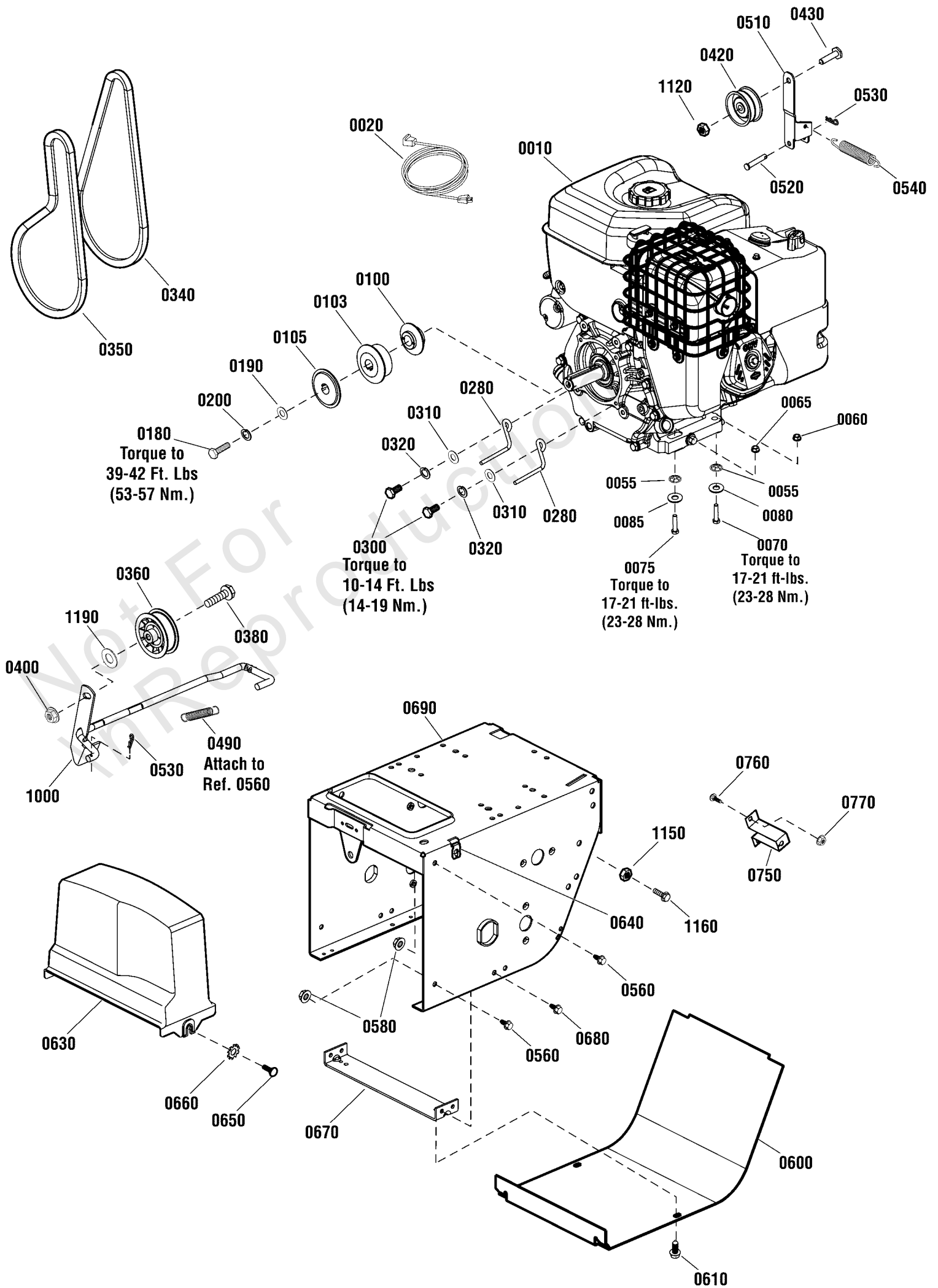

Engine & Frame Group - 21TP

REF NO	PART NO	QTY	DESCRIPTION
0010	25M317-0113-H1	1	* ENGINE, 21TP Briggs & Stratton -(Engine Model: 25M317-0113-H1)
0055	028X76MA	4	NUT, Speed
0060	1931211SM	3	NUT, Hex Flange, 3/8-16 -(Rear Engine Mount)
0065	703339	2	NUT, Hex Flange, Whiz Lock 7/16-14 -(Front Engine Mount)
0070	1921971SM	2	CAPSCREW, Hex Head, 3/8-16 x 1-3/4, G5 -(Rear Engine Mount)
0075	1923027SM	2	CAPSCREW, Hex Head, 7/16-14 x 1-3/4, G5 -(Front Engine Mount)
0080	71072MA	2	WASHER, Flat, 13/32 -(Rear Engine Mount)
0085	703183	2	WASHER, 7/16 -(Front Engine Mount)
0100	1755060YP	1	PULLEY, Crankshaft, Inside
0103	1726866SM	1	PULLEY, Engine, Middle
0105	1726867SM	1	PULLEY, Engine, Outer
0180	1922128SM	1	CAPSCREW, Hex Head, 3/8-24 x 1-1/2, G8
0190	1922755SM	1	WASHER, Flat, 1
0200	1916965SM	1	LOCKWASHER, Spring, 3/8
0280	1733014SM	2	STOP, Belt
0300	1921515SM	2	CAPSCREW, Hex Head, 5/16-24 x 3/4, G5
0310	1919326SM	2	WASHER, 5/16
0320	703116	2	LOCKWASHER, Spring, 5/16
0340	1754356YP	1	BELT, V, 4L, 43.35
0350	1753942YP	1	BELT, CVT, 3L, 32.90
0360	1726348SM	1	PULLEY, Idler, 2-3/4
0380	2860709SM	1	SCREW, Hex Flange, Whiz Lock, 3/8-16 1-3/4
0400	1928352SM	1	NUT, Hex Flange, Whiz Lock, 3/8-16
0420	1668477SM	1	PULLEY, Idler, With Bearing, 2-1/4 OD 0.378 ID
0430	1960647SM	1	SCREW, Hex Head, 3/8-16 x 1-1/2
0490	2159106SM	1	SPRING, Extension, 4-1/4"
0510	1703046BMYP	1	ARM, Idler
0520	1665994SM	1	PIN, 5/16 x 1-3/4
0530	1722460SM	2	HAIRPIN
0540	1727149SM	1	SPRING, Extension, 5.83"
0560	9357MA	4	SCREW, Whiz Lock, 5/16-18 x 3/4, G5
0580	1927557SM	4	NUT, Hex Flange, Whiz Lock, 5/16-18, G5
0600	1726870BSYP	1	COVER, Bottom
0610	1925003SM	2	SCREW, Hex Head, Taptite, 1/4-20 x 1/2
0630	1725287SM	1	COVER, Belt
0640	1935255SM	2	NUT, Speed, Lug Type, 5/16-18
0650	1918249SM	2	SCREW, 5/16-18 X 3/4, Slotted Truss Head, Blk
0660	7090395YP	2	WASHER, External Tooth, 5/16
0670	1727004BMYP	1	SUPPORT, Tie Bar
0680	703235	4	SCREW, Washer Head, 5/16-18 x 3/4
0690	1754350BSYP	1	FRAME
0750	1720404BMYP	1	SUPPORT, Clutch Cable
0760	1931317SM	2	BOLT, Carriage, Short Neck, 1/4-20 x 3/4, G5

Footnotes:

Note* See your local Briggs & Stratton distributor for parts and service.

Engine & Frame Group - 21TP

Note: Unless noted otherwise, use the standard torque specifications

Mfg. No: 1696257-01

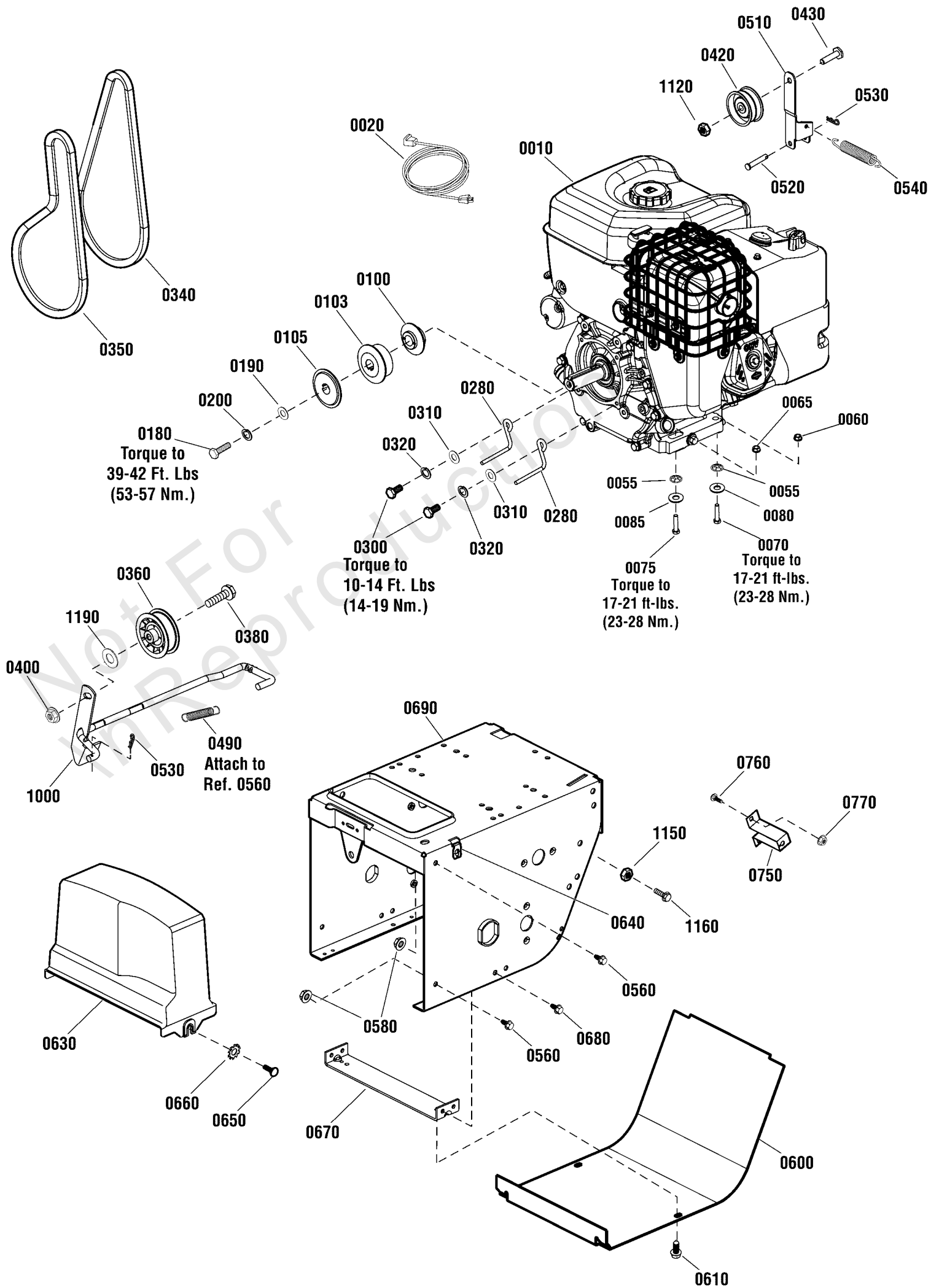

Engine & Frame Group - 21TP

REF NO	PART NO	QTY	DESCRIPTION
0770	1960685SM	2	NUT, KEPS, 1/4-20
1000	1729646BMYP	1	CLUTCH ROD
1120	1928731SM	1	NUT, Hex, Top Lock JAM, 3/8-16
1150	1920161SM	1	NUT, Hex, JAM 5/16-18
1160	001X84MA	1	CAPSCREW, Hex Head, 5/16-18 x 1
1190	1924874SM	1	WASHER, Flat, 5/16

Not For
In Reproduction

Footnotes:

Note* See your local Briggs & Stratton distributor for parts and service.

Gear Case Assembly (1732303)

Note: Unless noted otherwise, use the standard torque specifications

Mfg. No: 1696257-01

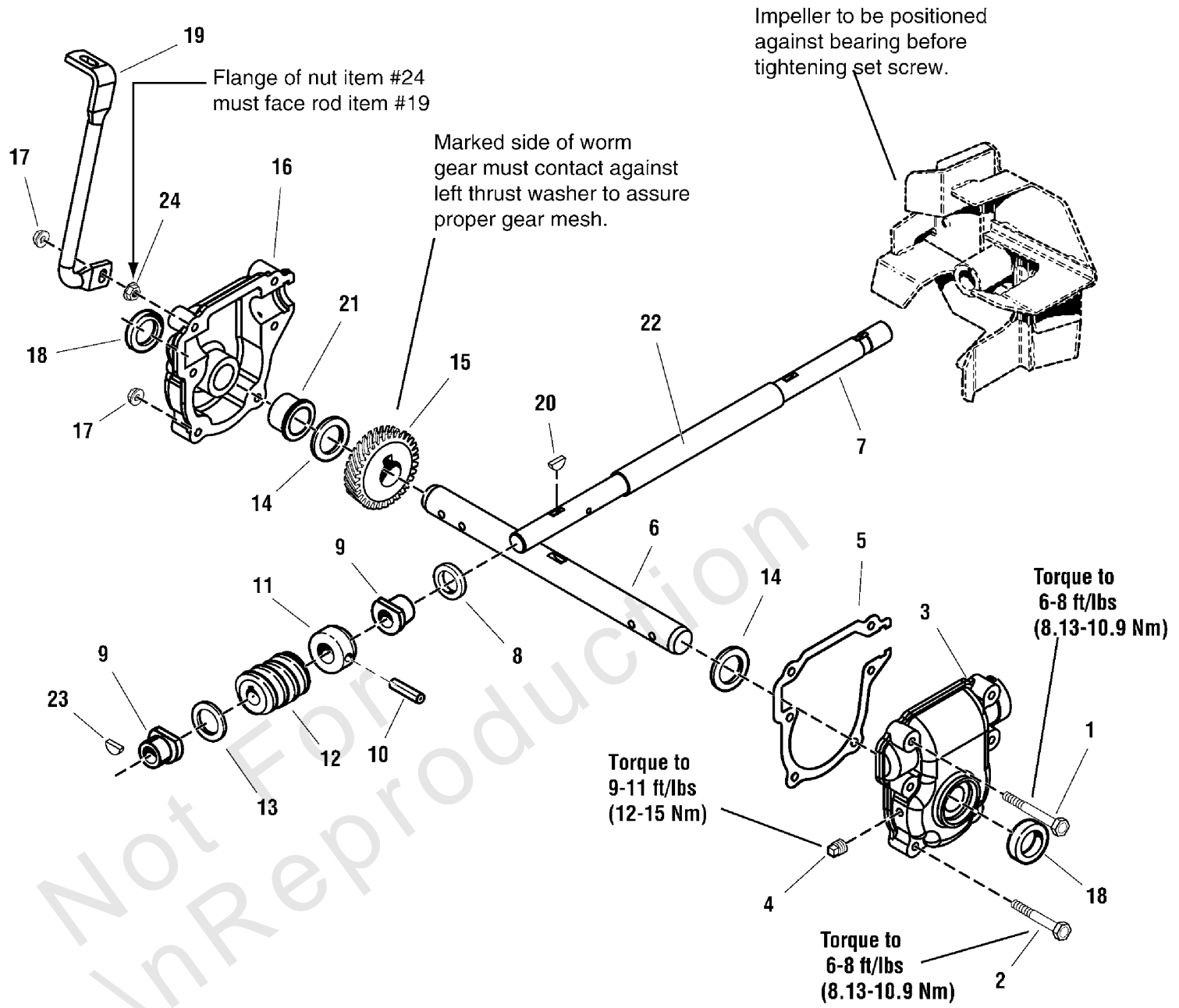

Gear Case Assembly (1732303)

REF NO	PART NO	QTY	DESCRIPTION
1	1923282SM	1	CAPSCREW, 1/4 - 20 x 2-1/2
2	1960346SM	5	CAPSCREW, 1/4-20 x 2-1/4
3	1612136SM	1	GEAR CASE, Left
4	1668971SM	1	TAPERED PIPE PLUG
5	1612124SM	1	GASKET
6	1732440SM	1	SHAFT, Auger Cutoff
7	1732182SM	1	SHAFT, Worm Cutoff
8	1612093SM	1	SEAL, Oil
9	1612149SM	2	FLANGE BUSHING
10	2836098SM	1	PIN, Drive Lock
11	1612127SM	1	THRUST COLLAR
12	1612142SM	1	ROLLED WORM CASE
13	2168111SM	1	WASHER, Thrust
14	2118315SM	2	WASHER, Thrust
15	1612141SM	1	GEAR, Worm
16	1612137SM	1	GEAR CASE, Right
17	1930642SM	6	NUT, Top Lock Flange, 1/4 - 20
18	2118118SM	2	SEAL
19	1732152SM	1	BRACKET, Wireform
20	2818312SM	1	KEY, Woodruff
21	1732991SM	2	BUSHING
22	1612111SM	1	TUBE
23	2830246SM	1	KEY, Woodruff
24	1960294SM	1	NUT, Flange, 1/4-20

Handle & Controls Group

REF NO	PART NO	QTY	DESCRIPTION
0010	1739686YP	1	LIGHT BAR ASSEMBLY
0010-10	-----	1	LENS, RH -(Not a serviceable part, included with Ref. No. 0010)
0010-20	-----	1	LENS, LH -(Not a serviceable part, included with Ref. No. 0010)
0010-30	1739689YP	2	LAMP, Halogen, JC4020 - PRISM JC20BA15S 12V 20W MINIMUM
0010-40	1736180YP	2	SOCKET & GASKET ASSEMBLY, Headlight
0010-50	-----	2	GASKET, Single, Twin Light -(Not a serviceable part, included with Ref. No. 0010-40)
0010-60	-----	2	BEZEL, Light, Panel -(Not a serviceable part, included with Ref. No. 0010)
0020	1739345BSYP	1	COVER, Panel, Remote Deflector
0030	1960556SM	9	SCREW, Pan Head, Torx, 1/4-20 x 3/4, Taptite
0040	1735643YP	1	CABLE & SPRING ASSEMBLY, Auger Drive, RH
0050	1735641AYP	1	HANDLE, Lower
0060	1737531AYP	1	HANDLE, Upper, R.H.
0070	1734586ASM	1	HANDLE, Upper, L.H.
0080	25X021MA	4	CAPSCREW, Hex Head, 5/16-18 x 3/4
0110	1960686SM	4	NUT, Flange, Nylock, 5/16-18
0120	1960273SM	2	BOLT, Carriage, 5/16-18 x 2-1/4
0130	7091189YP	2	BOLT, Carriage. 5/16-18 x 2, G2
0140	1920397SM	4	NUT, Hex Lock, 1/4-20
0150	703045	2	BOLT, Shoulder, 1/4-20 x 1 3/4 -(Use on Serial Numbers 2016551695 and Above)
0150	1678392SM	2	SPACER -(Use on Serial Numbers 2016551694 and Below)
0160	1921962SM	2	CAPSCREW, Hex Head, 1/4-20 x 1-3/4, G5 -(Quantity of 4 used on Serial Numbers 2016551694 and Below)
0170	1739783BMYP	1	LEVER, Clutch, RH
0180	1739782BMYP	1	LEVER, Clutch, LH
0190	1733505BMYP	1	BRACKET, Pivot, Free Hand
0200	1736360YP	1	ROD, Hold Down, 5/32 Dia., 5-5/8 Lg
0210	1733095SM	1	SPACER, 1/4 ID
0230	1736542YP	2	SPACER, Stepped
0240	1753529YP	2	BOLT, Shoulder, Hex Washer Head, 1/4 x 1-1/2
0250	1933896SM	2	NUT, Nylock, 10-24
0260	1738124YP	2	HAND GRIP
0265	703044	4	SCREW, Square, 1/8-20 x 1/32
0300	1750635YP	1	ROD, Speed Select
0310	1923701SM	1	CAPSCREW, Hex Head, 3/8-16 x 2, G5
0305	1666255SM	1	ROD, Shift
0320	1931277SM	3	NUT, Hex Flange Whiz Lock, 5/16-18
0308	1722460SM	1	HAIR PIN
0330	50786MA	1	SPRING, 1/2 Dia. x 3/4
0340	1918266SM	1	WASHER, 3/8 x 13/16 OD
0350	1919439SM	1	NUT, Hex Lock, 3/8-16
0390	1751352YP	1	BRACKET, Controls
0410	304437MA	1	KNOB, Slot Speed
0420	1917421SM	1	NUT, Hex Jam, 3/8-16
0430	703048	1	SPEED LEVER ASSEMBLY
0440	1735646YP	1	CABLE, Handle
0470	1736363YP	1	ROD & SPRING ASSEMBLY
0480	2108360SM	1	SPRING, Compression, 017/32 ID x 2-1/4 Lg

Handle & Controls Group

REF NO	PART NO	QTY	DESCRIPTION
0490	7091003YP	1	CAPSCREW, Hex Head, 1/4-20 x 1-3/4, G5
0495	703463	2	NUT, Nylock Flanged, 1/4-20
0500	1931333SM	3	BOLT, Carriage, 5/16-18 x 3/4
0510	1739500BMYP	1	SUPPORT, Dash
0520	1701011SM	5	TIE, SELF LOCKING, 7-5/16 Lg
0550	1931317SM	2	BOLT, Carriage, 1/4-20 x 3/4
0560	1960685SM	2	NUT, 1/4-20
0570	1750773YP	1	HARNESS
0575	1752164YP	1	HARNESS, On/Off, HHG
0580	1752242YP	1	SWITCH, Heated Hand Grip
0610	1739663BMYP	1	BRACKET, Mounting, Dash, R.H.
0620	1739664BMYP	1	BRACKET, Mounting, Dash, L.H.
0630	1739666BMYP	1	BRACKET, Light Mounting
0640	1739483AYP	1	POD, Chute Rotation, RH
0650	1739484AYP	1	POD, Deflector Control
0660	1739861AYP	1	BRACKET, Switch
0670	7091105YP	4	SCREW, Hex Washer Machine, #10-16 x 1/2
0700	1921319SM	4	WASHER, 1/4 x 5/8 OD
0710	1725702SM	1	SCREW, Pan Head Torx, #10 x 1/2
0720	1718791SM	1	CABLE & HANDLE ASSEMBLY
0750	1737552YP	1	BRACE
0760	1931317SM	1	BOLT, Carriage, 1/4-20 x 3/4
0770	1713588SM	1	SPACER
0780	1751392YP	1	SCREW, 1/4-20 x 2-1/4

Traction Drive Group

Note: Unless noted otherwise, use the standard torque specifications

Mfg. No: 1696257-01

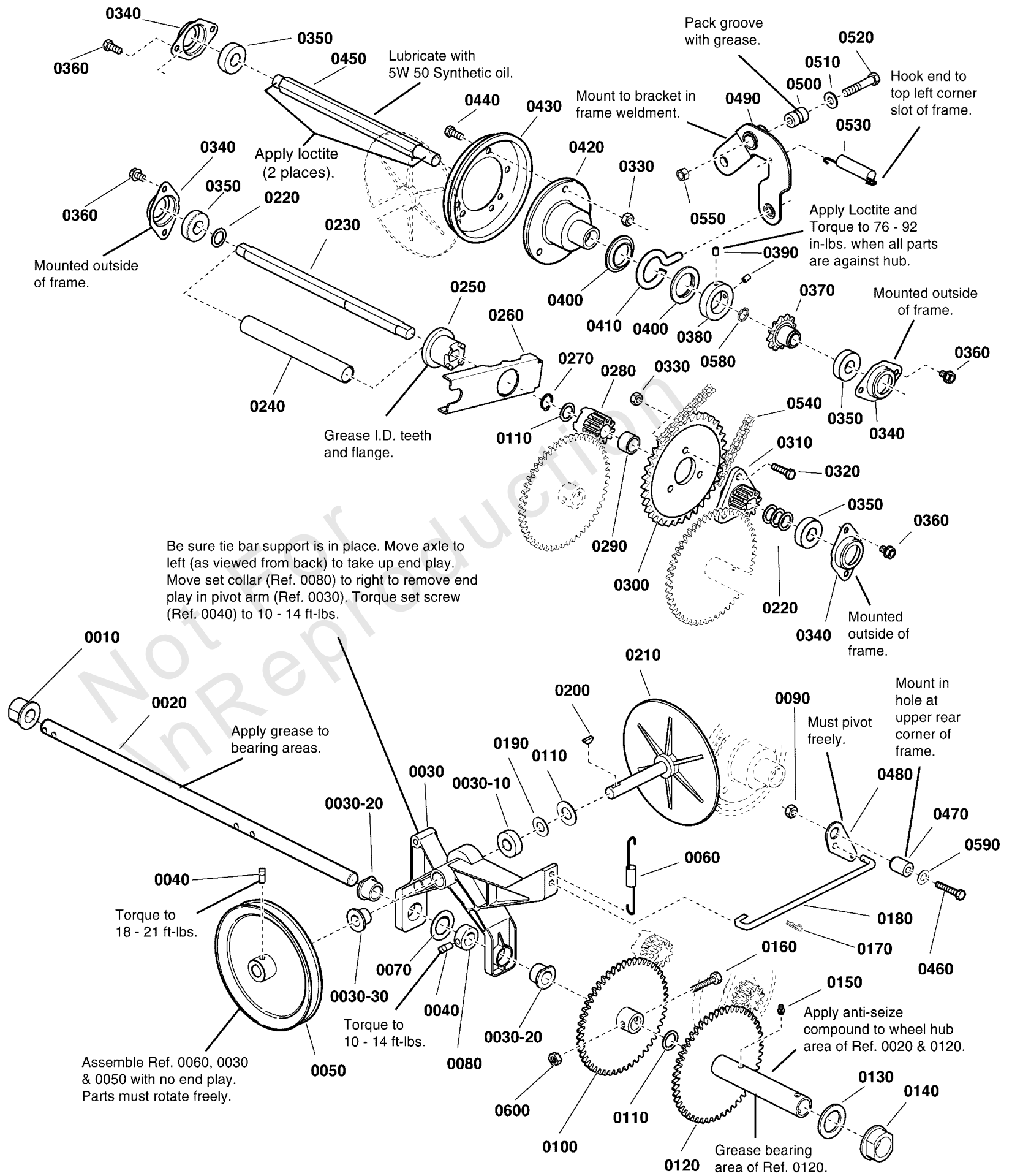

Traction Drive Group

REF NO	PART NO	QTY	DESCRIPTION
0010	1666001SM	1	BUSHING, 377/100 ID x 1-13/100 OD x 1 LG, Powdered Metal
0020	1736641YP	1	AXLE, 22-13/16 Long
0030	1670849SM	1	ARM ASSY., Pivot w/Bushings (Incl. all bushings, Qty 1 of Ref. No. 21, Qty 2 of Ref. No. 26; Qty. 1 of Ref. No. 37)
0030-10	1665521SM	1	BALL BEARING, Auger Axle
0030-20	1666425SM	2	BUSHING, 3/4 ID x 1 OD x 3/4 LG, Powdered Metal
0030-30	1666855SM	1	BUSHING, 5/8 ID x 13/16 OD x 3/4 LG, Powdered Metal
0040	1928721SM	2	SETSCREW, Square Head, 5/16-18 x 1/2, G8
0050	1672595SM	1	PULLEY AND HUB ASSEMBLY
0060	1725666SM	1	SPRING, Extension, 1/2 OD
0070	1919394SM	1	WASHER, 1, (As Required for All Front, As Required for K62 Rear)
0080	1729254SM	1	COLLAR, Set, .756 ID x 1.249 OD x .50
0090	1960686SM	1	NUT, Hex Flange Nylock, 5/16-18
0100	1736639YP	1	GEAR ASSEMBLY
0110	1960114SM	3	WASHER, 3/4 x 1
0120	1730228SM	1	GEAR AND HUB ASSEMBLY, with Bushings
0130	2860169SM	1	WASHER, 1-3/16
0140	1720305SM	1	BUSHING
0150	7076998SM	1	Fitting, Lube, Straight, 1/4-28
0160	706416	2	CAPSCREW, Hex-Head, 1/4-20 x 1-1/2, GR8
0170	1722460SM	1	PIN, Hair
0180	1726467SM	1	ROD, Pivot, 9-15/100 LG
0190	1924366SM	1	WASHER, 5/8
0200	2818312SM	1	KEY, Woodruff, 3/16 x 5/8
0210	1719879SM	1	DRIVE DISC with SPINDLE
0220	2860164SM	4	WASHER, Flat, 11/16" ID
0230	1718752SM	1	JACKSHAFT, Double D
0240	1720298SM	1	SPRING, Compression
0250	1718689SM	1	CLUTCH, Sliding, 1/5LG, Powdered Metal
0260	1720078ASM	1	ARM, Clutch
0270	2827732SM	1	RING, Retainer, Ext, # 74, 3/4 Dia.
0280	1718688SM	1	GEAR, 10 Tooth, Stationary, Clutch
0290	1679556SM	1	SPACER, Heat Treated, 31/100 LG
0300	1667330SM	1	SPROCKET, 36 Tooth
0310	1718687SM	1	GEAR, 10 Tooth, Double D
0320	1921333SM	3	CAPSCREW, Hex Head, 5/16-18 x 1
0330	1960684SM	6	NUT, Hex Keps, 5/16-18
0340	1667341SM	4	BEARING, Retainer
0350	771808	4	BEARING, Ball 11/16X1-9/16X15/32
0360	1930601SM	8	CAPSCREW, Hex Washer Head, Taptite, 5/16-18 x 5/8
0370	1726931SM	1	SPROCKET, 10 Tooth
0380	1667335SM	1	COLLAR, Set, 1.251 ID x 2.00 OD x .50 Long
0390	1960348SM	2	SET SCREW, Hex Socket, Cup Point, 1/4-20 x 3/8
0400	1678956SM	2	COLLAR, Thrust, 1-1/4 ID x 2 OD
0410	1666207SM	1	PIN, LOOP 3/8 Dia. x 2-3/32 Lg
0420	1665995SM	1	HUB, Friction Disc
0430	1725428SM	1	DISC, Friction with Insert
0440	1921332SM	3	SCREW, Hex Head Cap, 5/16-18 X 3/4, GR5
0450	1736100SM	1	SHAFT, Hex, 3/4 x 11-3/8 Lg, w/Groove
0460	1735776YP	1	CAPSCREW, Hex Socket-Head, 5/16-18 x 2, G8
0470	1666106SM	1	BUSHING, 11/32 ID x 3/4 OD, 1-1/16 Long

Traction Drive Group

Note: Unless noted otherwise, use the standard torque specifications

Mfg. No: 1696257-01

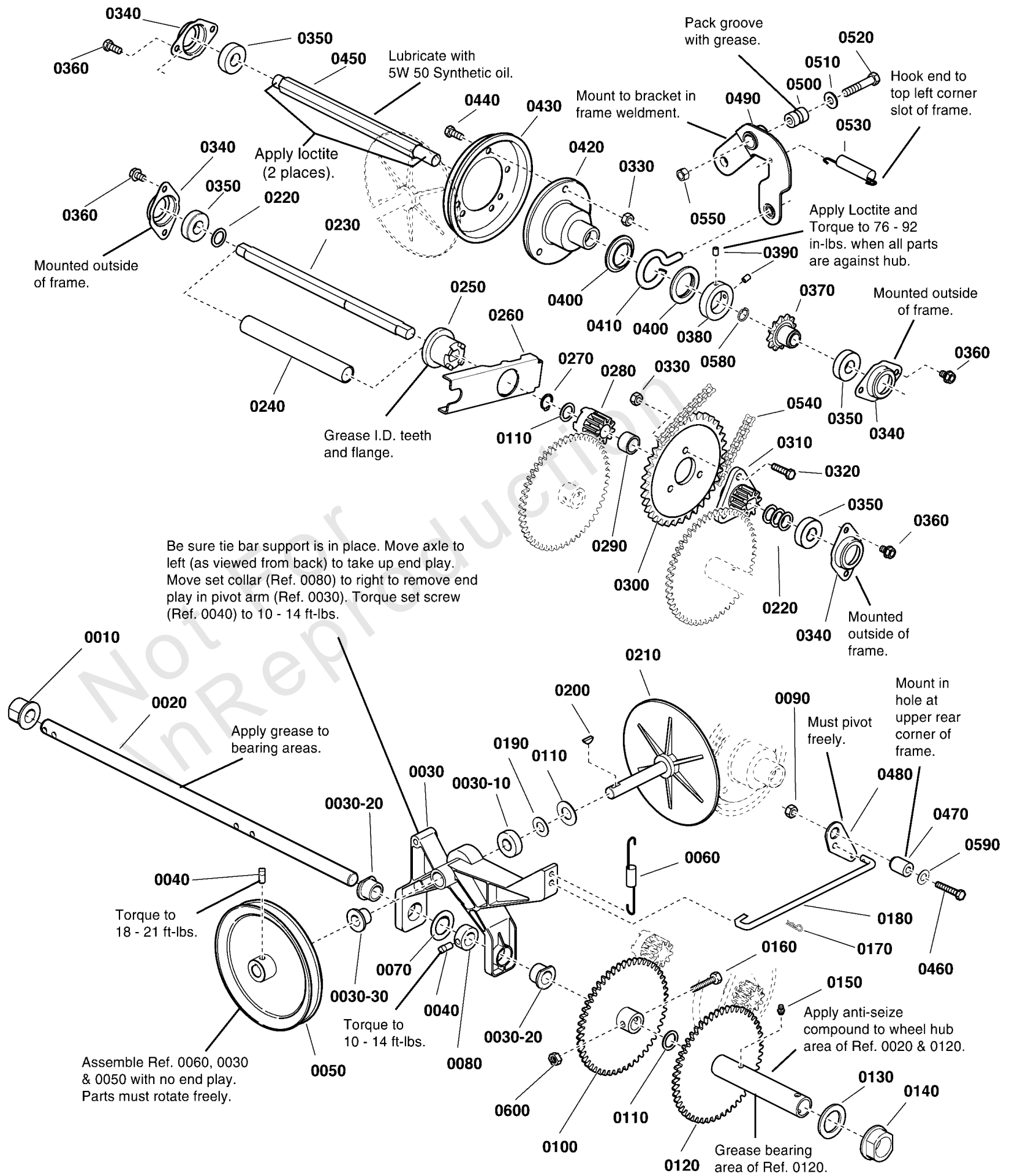

Traction Drive Group

REF NO	PART NO	QTY	DESCRIPTION
0480	1700473SM	1	BELLCRANK
0490	1669256SM	1	ARM ASSY., Shift w/Bushings (Includes Ref. No. 31)
0500	1666114SM	1	BUSHING, Spacer, .380 ID x .750 OD x 1.030 Long
0510	1924940SM	1	WASHER, 3/8, .41 ID x .87 OD x .08 THK
0520	1923701SM	1	CAPSCREW, Hex Head, 3/8-16 x 2, GR5
0530	1668255SM	1	SPRING, Extension
0540	1666980SM	1	CHAIN, Roller, 22" Lg
0550	1960687SM	1	NUT, Hex Flange Nylock, ESNA, 3/8-16
0580	1736222YP	1	RING, Retaining External #87
0590	1919326SM	1	WASHER, 5/16
0600	95661YP	2	NUT, Hex, Nylock 1/4-20

Not For In Reproduction

Wheels and Tires Group

Note: Unless noted otherwise, use the standard torque specifications

Mfg. No: 1696257-01

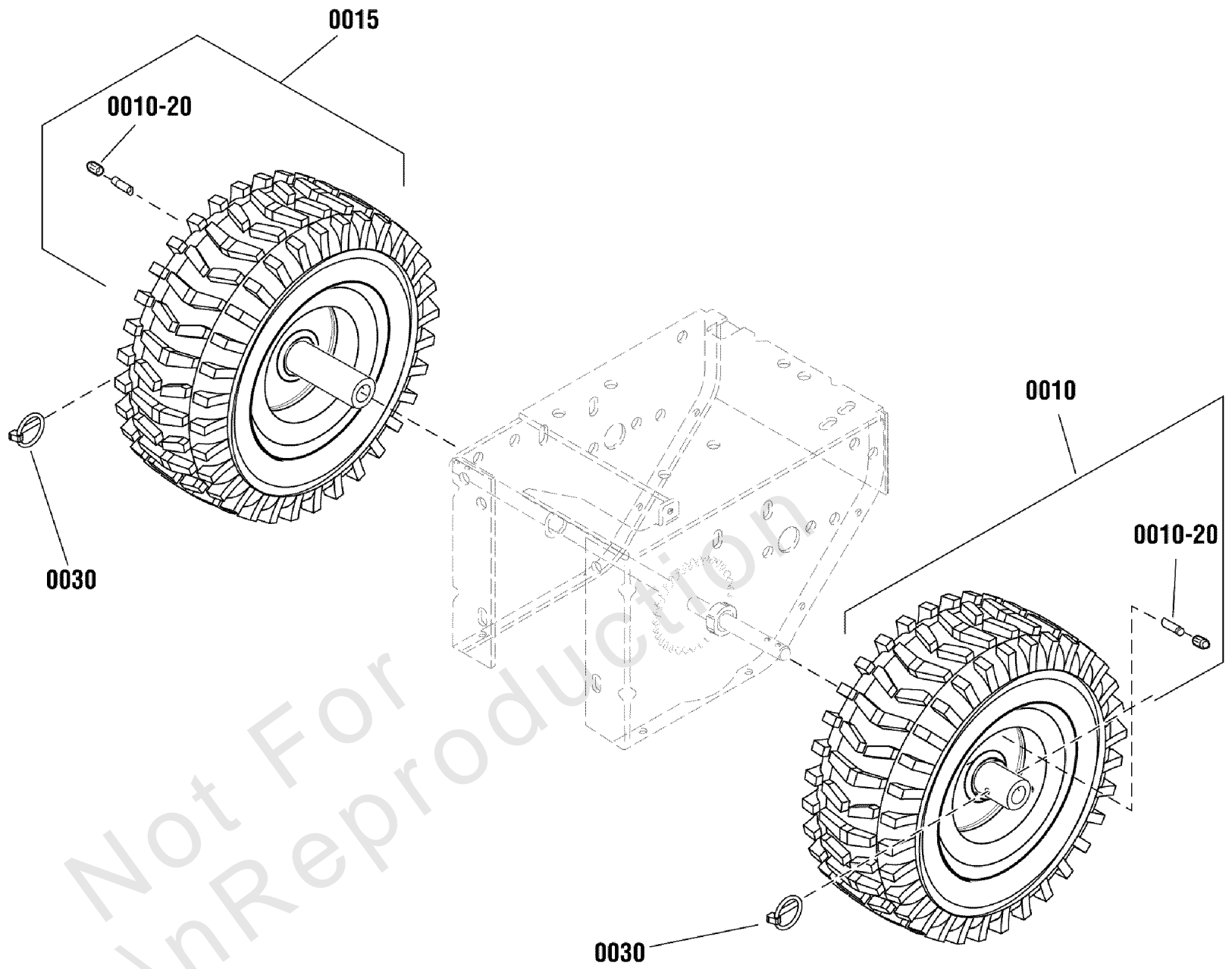

Wheels and Tires Group

REF NO	PART NO	QTY	DESCRIPTION
0010	1754529YP	1	WHEEL, 16 x 6.5, P2-407, L.H. -(Includes Ref. 0010-20)
0015	1754531YP	1	WHEEL, 16 x 6.5, P2-407, R.H. -(Includes Ref. 0010-20)
0010-20	2172353SM	2	VALVE STEM & CAP
0030	1731186SM	2	PIN, Klik, 2"

Not For In Reproduction

Hardware Identification & Torque Specifications

Torque Specification Chart								
FOR STANDARD METRIC MACHINE HARDWARE (Tolerance ± 20%)								
Property Class	5.6		8.8		10.9		12.9	
	Class 5.6		Class 8.8		Class 10.9		Class 12.9	
Size Of Hardware	in/lbs	Nm.	in/lbs	Nm.	in/lbs	Nm.	in/lbs	Nm.
	ft/lbs		ft/lbs		ft/lbs		ft/lbs	
M3	5.88	.56	13.44	1.28	19.2	1.80	22.92	2.15
M4	13.44	1.28	30.72	2.90	43.44	4.10	52.56	4.95
M5	26.4	2.50	60.96	5.75	5.97	8.10	7.15	9.7
M6	44.64	4.3	7.3	9.9	10.3	14	12.1	16.5
M7	5.2	7.1	12.1	16.5	16.9	23	19.9	27
M8	7.7	10.5	17.7	24	25	34	29	40
M10	15	21	35	48	50	67	59	81
M12	26	36	61	83	86.2	117	103	140
M14	42	58	101	132	136	185	162	220
M16	64	88	147	200	210	285	250	340
M18	89	121	202	275	287	390	346	470
M20	126	171	290	390	405	550	486	660
M22	169	230	390	530	559	745	656	890
M24	217	295	497	375	708	960	840	1140
M27	320	435	733	995	1032	1400	1239	1680
M30	435	590	995	1350	1401	1900	1681	2280
M33	590	800	1349	1830	1902	2580	2278	3090
M36	759	1030	1740	2360	2441	3310	2935	3980
M39	988	1340	2249	3050	3163	4290	3798	5150

Torque Specification Chart						
FOR STANDARD MACHINE HARDWARE (Tolerance ± 20%)						
Hardware Grade	No Marks		SAE Grade 5		SAE Grade 8	
	SAE Grade 2		SAE Grade 5		SAE Grade 8	
Size Of Hardware	in/lbs	Nm.	in/lbs	Nm.	in/lbs	Nm.
	ft/lbs		ft/lbs		ft/lbs	
8-32	19	2.1	30	3.4	41	4.6
8-36	20	2.3	31	3.5	43	4.9
10-24	27	3.1	43	4.9	60	6.8
10-32	31	3.5	49	5.5	68	7.7
1/4-20	66	7.6	8	10.9	12	16.3
1/4-28	76	8.6	10	13.6	14	19.0
5/16-18	11	15.0	17	23.1	25	34.0
5/16-24	12	16.3	19	25.8	29	34.0
3/8-16	20	27.2	30	40.8	45	61.2
3/8-24	23	31.3	35	47.6	50	68.0
7/16-14	30	40.8	50	68.0	70	95.2
7/16-20	35	47.6	55	74.8	80	108.8
1/2-13	50	68.0	75	102.0	110	149.6
1/2-20	55	74.8	90	122.4	120	163.2
9/16-12	65	88.4	110	149.6	150	204.0
9/16-18	75	102.0	120	163.2	170	231.2
5/8-11	90	122.4	150	204.0	220	299.2
5/8-18	100	136	180	244.8	240	326.4
3/4-10	160	217.6	260	353.6	386	525.0
3/4-16	180	244.8	300	408.0	420	571.2
7/8-9	140	190.4	400	544.0	600	816.0
7/8-14	155	210.8	440	598.4	660	897.6
1-8	220	299.2	580	788.8	900	1,244.0
1-12	240	326.4	640	870.4	1,000	1,360.0

The guides and ruler furnished below are designed to help you select the appropriate hardware.



Nut, M8

Thread Diameter (mm)

Inside Diameter (in) Threads per inch

Nut, 1/2-16

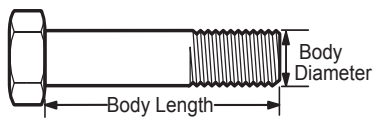

Screw, M8- 1.25 x 25

Thread Diameter (mm) Distance between threads (mm) Body Length (mm)

Body Diameter Threads per inch Body Length (in)

Screw, 1/2- 16 x 2



Standard Hardware Sizing

When a washer or nut is identified as 1/2" (M8), this is the *Nominal size*, meaning the *inside diameter* is 1/2 inch (8mm metric thread diameter); if a second number is present it represents the *threads per inch* (distance between threads).

When bolt or capscrew is identified as 1/2 - 16 x 2" (M8 - 1.25 x 50), this means the *Nominal size*, or body diameter is 1/2 inch (8mm metric thread diameter), the second number, 16, represents the *threads per inch*, (*distance between threads*). The final number is the body length of the bolt or screw, 2 inches (50mm).

NOTES

- These torque values are to be used for all hardware excluding: locknuts, self-tapping screws, thread forming screws, sheet metal screws and socket head setscrews.
- Recommended seating torque values for locknuts:
 - for prevailing torque locknuts - use 65% of grade 5 torques.
 - for flange whizlock nuts and screws - use 135% of grade 5 torques.
- Unless otherwise noted on assembly drawings, all torque values must meet this specification.

Common Hardware Types

Hex Head Capscrew



Washer



Carriage Bolt



Hex Nut

Wrench & Fastener Size Guide

1/4" Bolt or Nut Wrench—7/16"	5/16" Bolt or Nut Wrench—1/2"	3/8" Bolt or Nut Wrench—9/16"	7/16" Bolt or Nut Wrench (Bolt)—5/8" Wrench (Nut)—11/16"	1/2" Bolt or Nut Wrench—3/4"
M6 Bolt or Nut Wrench—10mm	M8 Bolt or Nut Wrench—13mm	M10 Bolt or Nut Wrench—17mm	M12 Bolt or Nut Wrench—19mm	M14 Bolt or Nut Wrench—22mm

